



Anets Platinum (AGP) SERIES
55, 55T, 60, 60W, 75 Gas Fryers

Project _____

Item No. _____

Quantity _____

Anets Platinum (AGP) SERIES 55, 55T, 60, 60W, 75 Gas Fryers

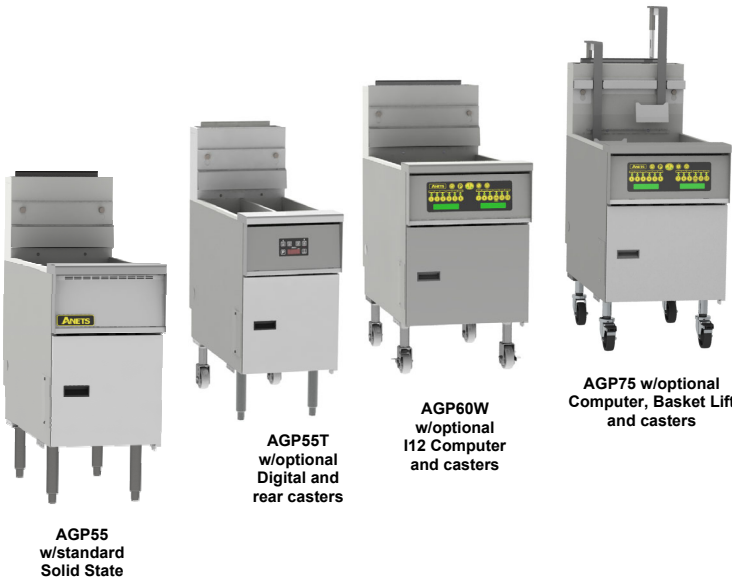

HIGH EFFICIENCY SERIES OF GAS FRYERS

Model AGP55,55T,60,60W,75 tube fired gas fryers with atmospheric burner technology which provides very dependable heat transfer performance without the need for complex power blowers. This patented atmospheric burner system with its long lasting alloy heat baffles reaches up to 70% thermal efficiency and delivers lower flue temperatures. New Patented Self Cleaning Burner goes through a daily 30 second cleaning cycle to keep your burners tuned to operate in the most energy efficient manner. Ventilation troubles are virtually eliminated with the Patented Down Draft Protection that safely monitors your fryer, making this a low maintenance, highly reliable fryer. High volume restaurants and multi-store chains can benefit from lower operational energy cost and lower annual maintenance and repair cost.

MODELS AVAILABLE

AGP55 Series (40-50 lbs, 14" x 14" fry area)

- AGP55 (80K btu/hr, 23.4 kW, 88 MJ /side)

AGP55T Twin Vat Series (20-25 lbs, 7" x 14" fry area/side)

- AGP55T (40K btu/hr, 11.7 kW, 44 MJ /side)

AGP60 Series (50-60 lbs, 14" x 18" fry area)

- AGP60 (80K btu/hr, 23.4 kW, 88 MJ)

AGP60W Series (50-60 lbs, 18" x 14" fry area)

- AGP60W (100K btu/hr, 29.3 kW, 110 MJ)

AGP75 Series (75 lbs, 18" x 18" fry area)

- AGP75 (105K btu/hr, 30.8 kW, 116 MJ)

STANDARD FEATURES & ACCESSORIES

- Tank - stainless steel construction
- Cabinet - stainless front, door and sides
- Atmospheric burner/baffle design
- High Efficiency design, EnergyStar performance
- Patented Self Cleaning Burner & Down Draft Protection
- Solid State T-Stat with melt cycle & boil out mode
- Matchless Ignition automatically lights the pilot when the power is turned on and saves you money during off times
- DVI drain valve interlock safety system turns the heat off preventing the oil from scorching / overheating.
- High Temperature safety limit switch
- Heavy duty 3/16" bottom door hinge
- 1 1/4" (3.2 cm) Full port drain valve for fast draining
- Separate Manual gas shutoffs, for front servicing
- Integrated flue deflector
- 9" (22.9 cm) adjustable legs, easier access to clean
- Tube rack, allows crumbs & debris into cool zone
- Removable basket hanger, requires no tools
- Drain Line Clean out rod
- Drain Extension
- Fryer cleaner sample packet
- Choice of basket options:
 - 2-Twin Baskets
 - 1-Full Basket (not available on 55T or Basket Lifts)

OPTIONS & ACCESSORIES (AT ADDITIONAL COST)

- Digital Controller (2 timers w/melt cycle)
- I-12 Button Controller (12 Button menu)
- Backup thermostat (only on Digital and I-12 Button)
- Basket Lift (must be ordered with Digital Control or Computer) (To meet AGA/CGA/CSA specification, must be ordered with casters & installed with flexible gas hose w/restraining cable)
- Stainless Steel back (not available with basket lift)
- 9" (22.9 cm) adjustable, non-lock rear & front lock casters
- Flexible gas hose with disconnect and restraining cable
- Tank cover
- 3-Triple Baskets (not available on 55T or Basket Lifts)
- Consult Factory for other basket configurations
- Splash Guard reversible (L/R) 6" 8" 12" 18"
- Work Shelves call factory for specifications and availability
- Fish Grids (not available on 55T)
- Institutional Prison security package
- Filter System options (See Spec Sheet):
 - Filter drawer
 - SoloFilter



Anets Platinum Models (AGP) 55, 55T, 60, 60W, 75 Gas Fryers

	AGP55 AGP55T	AGP75	APG60	AGP60W
A	48 11/32 [122.8]	52 11/32 [132.9]	48 11/32 [122.8]	52 11/32 [132.9]
B	15 5/8 [39.7]	19 5/8 [49.8]	15 5/8 [39.7]	19 5/8 [49.8]
C	4 1/4 [10.8]	6 1/4 [15.9]	4 1/4 [10.8]	6 1/4 [15.9]

(G) 3/4 INCH GAS CONNECTION
(CE 3/4 INCH BSP ADAPTOR
ADDS 1 1/2 [3.8] TO
CONNECTION)

(P) 6 FOOT (183 CM) POWER
CORD (NEMA 5-15 PLUG
115VAC UNITS ONLY)

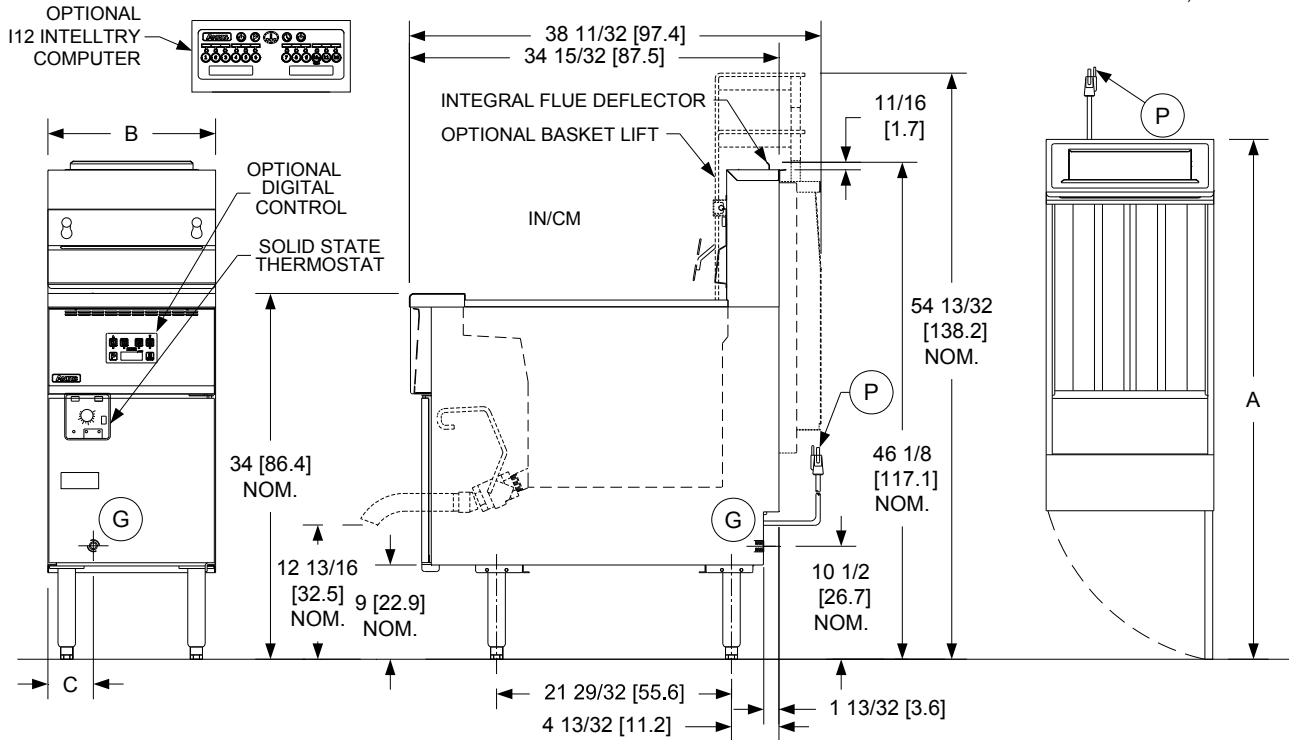

Anets Platinum Models (AGP) 55, 55T, 60, 60W, 75 Gas Fryers

INDIVIDUAL FRYER SPECIFICATIONS							
Model	Frying Area		Cook Depth		Oil Capacity		
AGP55	14 x 14 in (35.6 x 35.6 cm)		3-1/4 - 5 in (8.3 - 12.7 cm)		40 - 50 Lbs (18 - 23 kg)		
AGP55T per side	7 x 14 in (17.8 x 35.6cm)				20 - 25 Lbs (9 - 11 kg)		
AGP60	14 x 18 in (35.6 x 45.7 cm)				50 - 60 Lbs (23 - 27 kg)		
AGP60W	18 x 14 in (45.7 x 35.6 cm)				50 - 60 Lbs (23 - 27 kg)		
AGP75	18 x 18 in (45.7 x 45.7 cm)				75 Lbs (34 kg)		
FRYER SHIPPING INFORMATION (Approximate)							
Model	Shipping Weight	Add for Each Bsk/Lifts	Shipping Crate Size H x W x L			Shipping Cube	
AGP55	208 Lbs (94.5 kg)	308 Lbs (140 kg)	59 x 23 x 44 in (149.8 x 58.4 x 111.7 cm)			34.6 ft ³ . (1.0m ³)	
AGP55T	230 Lbs (104 kg)	330 Lbs (150 kg)					
AGP60	226 Lbs (102.5 kg)	326 Lbs (149 kg)					
AGP60W	275 Lbs (124.5 kg)	376 Lbs (171 kg)					
AGP75	275 Lbs (124.5 kg)	376 Lbs (171 kg)					
INSTALLATION INFORMATION							
GAS SYSTEM REQUIREMENTS				ELECTRIC SYSTEM REQUIREMENTS (50/60 hz)			
Gas Type	Store Supply Pressure *	Burner Manifold Pressure	Amps	# of Cord	115V	208 / 220-240V	
Natural	7 - 10" w.c.(17.4 mbars/ 1.7 kPa)	4" w.c. (10 mbars / 1 kPa)	Fryer	1	0.7	0.4	
Propane	11 - 13" w.c.(27.4 mbars/ 2.7 kPa)	10" w.c. (25mbars/2.4 kPa)					
* Check plumbing / gas codes for proper gas supply line sizing to sustain burner pressure when all gas appliances are full on.							
CLEARANCES							
Front min.	Floor min.	Combustible material		Non-Combustible material		Fryer Flue Area	
30" (76.2 cm)	6" (15.25 cm)	Sides min.	Rear min.	Sides min.	Rear min.	Do not block / restrict flue gases from flowing into hood or install vent hood drains over the flue.	
		6" (15.2cm)	6" (15.2cm)	0"	0"		
SHORT FORM SPECIFICATIONS							
Provide Anets Model (AGP xxx) tube fired high efficiency / high production gas floor fryer with ENERGYSTAR [®] performance. Fryer shall be xx-xx lbs oil capacity, xxx Kbtu/hr, xx" by xx" fry area, stainless peened tank, stainless front, door, sides. Patented Blower Free atmospheric burner system with up to 70% thermal efficiency, Patented self cleaning burners, down draft protection, matchless ignition, drain valve interlock, behind the door solid state t-stat with melt and boil mode (or specify optional digital controller or computer controls), separate gas shut off, 3/4" npt rear gas connect, recessed cabinet back, 1-1/4" Full port drain, 3/16" bottom hinge, 9" adjustable legs, manual reset high limit. If supplied with casters: Casters with 1" min. adjustment and front toe locks. Provide options and accessories as follows:							

Anets P.O. Box 501, Concord, NH 03302-0501 • 553 Route 3A, Bow, NH 03304

603-225-6684 • FAX: 603-225-8497 • www.anets.com 156-000024 Rev 0 12/19 Printed in the USA

We reserve the right to change specifications without notice and without incurring any obligation for equipment previously or subsequently sold.